

... from development to
implementation

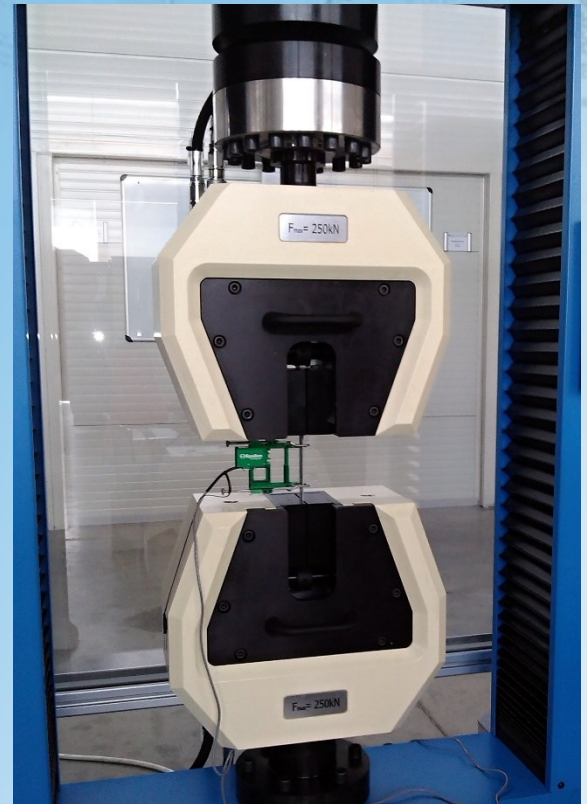

Production of materials testing equipment and automation

Wedge grips with hydraulic pressure



Made in Czech Republic

Wedge grips with hydraulic pressure

Main features and advantages

- The grips series consists of types according to the following load of 100, 250, 400, 600k, 1000 and 2500 kN.
- Robust grips body enables attaching the other grips without disabling them.
- Easy to change inserts by opening the front cover and sliding into the dovetail groove of the holder.
- Practical adjustment of centering of flat samples thanks to mechanical stop and ruler.
- Adjustable compression force via hydraulic valve.
- Possibility of opening and closing the grips by remote control, pedals or software.
- In conjunction with the LABORTECH test software; The zero-force regulation is enabled during clamping of the test specimen.
- Mechanical connection with flange preparation allows for variability of use.

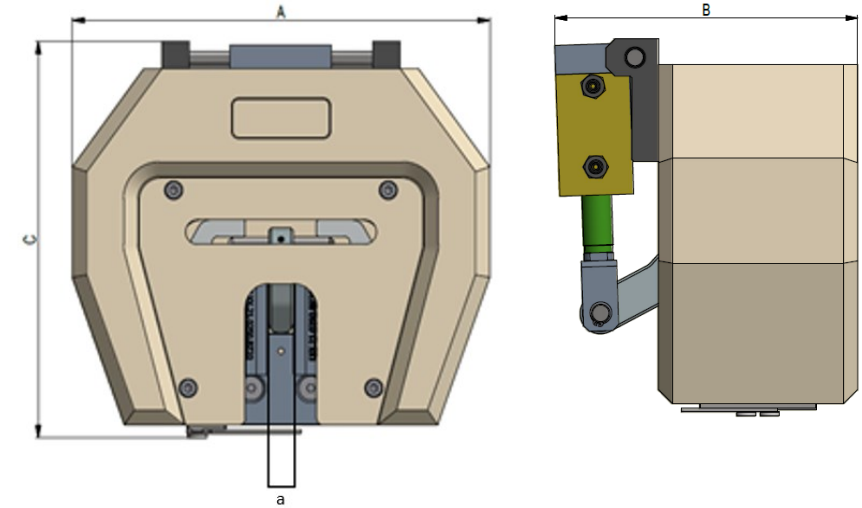

1. L13 – Wedge grips with hydraulic pressure

| Technical data | | | | | | Ordering information | Inserts for grips | | | | | | | | | |
|----------------|---------------|---------------------|-----|-----|--------|----------------------|-------------------|--|-------|--------|------|---|-------|--------|---------|------|
| Load | Clampin angle | External dimensions | | | Weight | | Signature type | Pyramid inserts 1.2x45° or transverse grooving | | | | Prizmatic inserts with transverse grooving with notches | | | | |
| Fmax | a | A | B | C | kg | Opening | | | | | | | | | | Dim. |
| kN | mm | mm | mm | mm | | | mm | | | | | | | | | |
| 100 | 0 - 50 | 280 | 140 | 265 | 70 | 2.0413022417 | 0-20 | 18-38 | 32-50 | / | 4-20 | 20-36 | 34-50 | / | 58x60 | |
| 250 | 0 - 55 | 350 | 285 | 290 | 110 | 2.0413024117 | 0-20 | 18-38 | 36-55 | / | 4-20 | 20-38 | 38-55 | / | 80x80 | |
| 300/400 | 0 - 60 | 420 | 244 | 355 | 267 | 2.0413025817 | 0-15 | 15-30 | 30-45 | 45-60 | 5-20 | 15-30 | 30-45 | 45-60 | 100x100 | |
| 500/600 | 0 - 60 | 460 | 244 | 397 | 293 | 2.0413027417 | 0-15 | 15-30 | 30-45 | 45-60 | 5-20 | 15-30 | 30-45 | 45-60 | 100x100 | |
| 1 000 | 0-100 | 660 | 240 | 457 | 542 | 2.04130212717 | 0-34 | 32-64 | 62-94 | 85-105 | 5-34 | 34-60 | 55-80 | 80-105 | 100x130 | |
| 1200 | 0-100 | 660 | 240 | 457 | 542 | 2.04130221820 | 0-34 | 32-64 | 62-94 | 85-105 | 5-34 | 34-60 | 55-80 | 80-105 | 100x130 | |
| 2 500 | 0-100 | 800 | 345 | 643 | 1090 | 2.04130218920 | 0-35 | 30-60 | 50-80 | 70-100 | 0-35 | 30-60 | 50-80 | 70-100 | 160x160 | |

Labor Tech

Production of materials testing equipment and automation

Wedge grips with hydraulic pressure

... from development to realization

LABORTECH in the world



Contact:

LABORTECH s.r.o.

Rolnická 130a, 747 05 Opava, Česká republika

Tel: +420 553 731 956, +420 553 668 648

E-mail: info@labortech.cz

Web: www.labortech.cz

GPS: 49°57'05.1"N

17°54'04.4"E

LABORTECH TRADING s.r.o.

Areál VVÚD Praha, Na Florenci 1686/9, 111 71 PRAHA 1, Česká republika

Tel: +420 731 656 723, +420 724 020 052

E-mail: trading@labortech.cz

Web: www.labortech.eu

Labor Tech

Production of materials testing
equipment and automation

LABORTECH
In the world

... from development to
implementation