

... From development to  
implementation



## Production of materials testing equipment and automation

Testing machines for long-term tests  
**CREEP TEST LabTest C.1-C.2**  
**up to 100 kN**



Made in Czech Republic



Production of materials testing equipment and automation

## Testing machines for long-term tests CREEP TESTS LabTest C.1-C.2 up to 100 kN

... From development to implementation

### Basic description

The electromechanical testing machines of C.1 - C.2 series in a vertical floortop design up to 100kN, maintaining a constant load by means of a spring or lever mechanism and a force load cell, gravity power. These machines are designed to perform long-term CREEP tests, creep determination, relaxation of material stress, etc. This series of machines is characterized by high rigidity of the frame, cohesiveness and mechanical resistance.



### Main advantages and functions

- The ideal ergonomic design of the machine allows the operator to easily perform long-term tests.
- Robust vertical four-column frame with high rigidity, alignment, resistance, durability and maintenance-free operation.
- Special lever mechanism with one or two ratios with almost zero friction, no wear and continuous application of force.
- Mechanism for setting the relative zero of the load mechanism.
- Machine design in accordance with EN ISO 204, ASTM E 292 and ASTM E139.
- Automatic lever fixation after sample breakage
- Automatic weight set fixation
- Integrated tripod for blast furnace
- Mechanical multifunctional drive system for basic settings
- Accuracy class 1 according to EN ISO 7500-2 within the range of 1 to 100% of rated load.
- A set of calibrated weights with class F1 with a maximum unit of 200N
- Modular arrangement of the machine with the possibility of adding any LABORTECH accessories, including extensometers, high-temperature furnaces, temperature chambers, probes, fixtures, cooling circuits, etc.

- Control and display electronics SIEMENS in the machine base. Test progress displayed on a color LCD monitor.
- Integrated LOTETest software in the machine base.
- Possibility to extend the machine with CREEPTest - BASIS software and add-on modules for mass testing of multiple machines.
- Modification of machine frame to various widths, heights and depths according to customer requirements (OPTION)



### Measuring and control machine electronics

- Long-term reliable, accurate measuring and control electronics of the EDCi series with an integrated UPC unit ensuring data conservation in the event of a power failure. Sampling system with frequency up to 5kHz, 64bit internal accuracy, 32bit measurement and 24bit resolution ADCs.
- Modular system with possibility to extend measurement up to 16 sensors. SAFETY with new safety functions according to ENB ISO 13850-SIL 1 / PL.

### Force measuring system

- The C-series load cells are ideal for tensile, compression, bending and cyclic tests. They are characterized by high resistance to lateral forces, bending moments and high overload resistance. Accuracy class according to EN ISO 7500-1, ASTM E4 is commonplace. Each sensor is equipped with an SGS connector with an integrated EEPROM to which the calibration constant and linearization can be configured.
- The accuracy class of the load cells supplied by us is 0,5 or 1.
- The load cell type is always chosen according to the type of the testing and test fixtures used.

### Basic features of LOTETest® software

- Intelligent and intuitive software included in the price of the machine base (with option to upgrade on version CREEPTest-BASIS software), designed to collect data and view measured values from track, force, sample and high temperature chambers while performing long-term CREEP tests over time.
- Digital display of all actual values of active channels, Test run graph.
- Saving of measured data into database with possibility of filtering according to definition, order, date etc.



### Upgraded software model CREEPTest - BASIS®

- Software designed for long-term testing CREEP with full automation of the test process and elimination of errors during long-term tests according to EN-ISO, ASTM, GOST standards.
- Simple intuitive operation, continuous collection, remote monitoring of test process, statistical processing of results and analysis of tests, database storage of results, data backup, possibility to generate own methods and test templates, automation of error reports, graphical processing of tests.
- Data export to CSV – BASIS, or to MY SQL and MS SQL
- 9 language versions (Cz, En, Ge, Fr, Pol, It, Sp, Ru, Du)
- Service menu

### Safety and service life requirements

- LABORTECH machines, based on their design and construction, comply with all of the above EC Machinery and Equipment Directives.
- The customer always receives an EC declaration of conformity.
- Only state-of-the-art safety technology and proven industrial components operating in accordance with the new ENB ISO 13850-SIL 1 / PL safety features are used.
- Spare parts are available 10 years after the end of the machine type production.

**Labor Tech**

Production of materials testing equipment and automation

Testing machines for long-term tests CREEP TESTS LabTest C.1-C.2 up to 100 kN

... From development to implementation

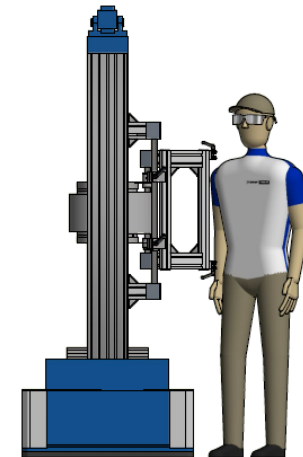
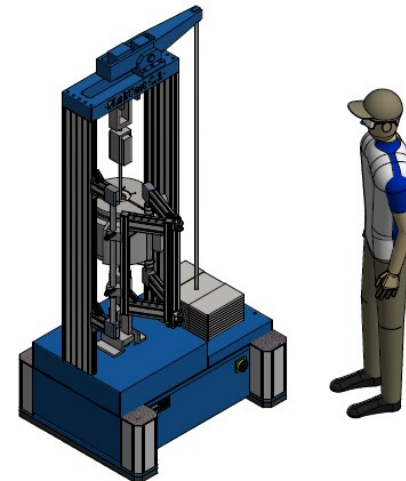
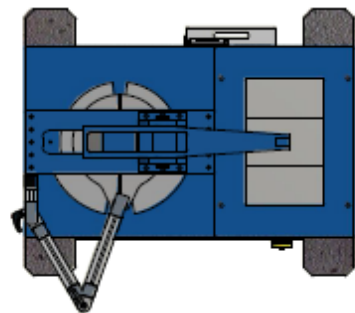
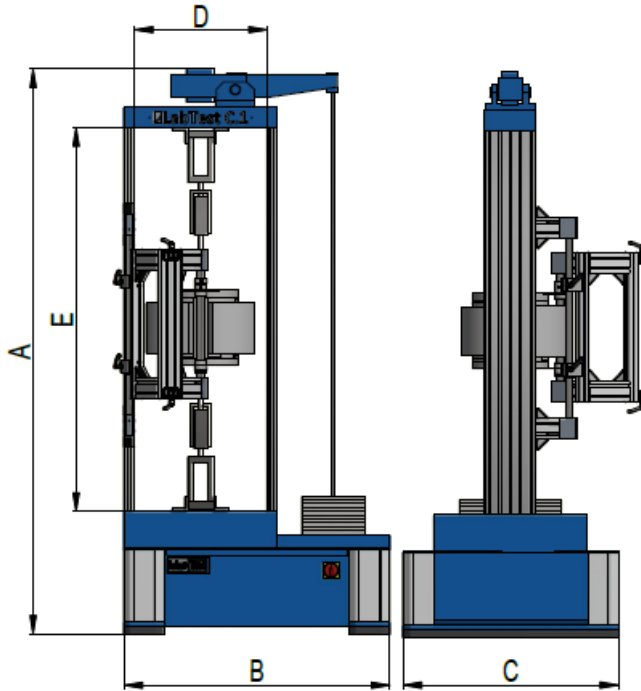

Technical data	Units	CREEPTest 6.30C.1	CREEPTest 6.50C.1	CREEPTest 6.100C.1	CREEPTest 6.30C.1C	CREEPTest 6.30C.2	CREEPTest 6.50C.2	CREEPTest 6.100C.2
Nominal load	kN	30	50	100	30	30	50	100
Load cell accuracy	%	±0,5/1 <sup>3</sup>						
Weight <sup>1</sup>	kg	615	615	620	615	615	615	620
<b>Dimensions</b>								
Machine height (A)	mm	2210						
Machine width (B)	mm	1040						
Machine depth (C)	mm	840						
Width of workspace (D)	mm	1500						
Height of workspace (E)	mm	520						
<b>Environmental conditions</b>								
Work environment temperature	°C	od 10 do 35						
Storage temperature	°C	od -35 do 55						
Humidity range	%	< 90						
Noise level <sup>2</sup>	dB	< 65						
<b>Electrical connection</b>								
Supply voltage	V	230V, 400V/50Hz						

<sup>1</sup> The machine weight is without of testing inserts and Load cell. <sup>2</sup> Machine noise is measured 1 m from the test machine <sup>3</sup>When used as an accessory.

# LABORTECH in the world



## Contact:

### **LABORTECH s.r.o.**

Rolnická 130a, 747 05 Opava, Czech Republic

Phone: +420 553 731 956, +420 553 668 648

E-mail: [info@labortech.cz](mailto:info@labortech.cz)

Web: [www.labortech.cz](http://www.labortech.cz)

GPS: 49°57'05.1"N

17°54'04.4"E

### **LABORTECH TRADING s.r.o.**

Areál VVÚD Praha, Na Florenci 1686/9, 111 71 PRAHA 1, Czech Republic

Phone: +420 731 656 723, +420 724 020 052

E-mail: [trading@labortech.cz](mailto:trading@labortech.cz)

Web: [www.labortech.eu](http://www.labortech.eu)

**Labor Tech**

Production of materials testing  
equipment and automation

LABORTECH in the  
world

... from development to  
implementation