

Product Information

Servo-Hydraulic Vertical Static Four Column Testing Machines LabTest 6.xxxH.2 up to 1500kN

Machine use

Servo-hydraulic testing machines of the H.2 series are designed for safe and effective testing of materials and whole products in tensile, compression, bending, shear and special testing of high-strength materials.. This machine series is characterized by high durability and mechanical resistance. The basic equipment of machine includes central-placed, quiet and economical hydraulic drive. Thanks to a wide range of accessories for H.2 series it is possible to test any materials or products at maximum capacity of 1500 kN.

Machine description and the main advantages

- Open, four columns frame with high durability and ideal ergonomic configuration.
- Machine and working area ergonomic with sufficient width allows easy manipulation with specimens and accessories.
- Robustness of the frame ensures high rigidity, durability and resistance against vibration and mechanical damage.
- Quiet hydraulic drive with low noise <68 dB and low power consumption, automatic controlling of hydraulic unit parameters and air cooling.
- Automatic check of the controlled loading of power and position loop with proportional servo valve support.
- A modular configuration of the machine with the ability to add any accessories from LABORTECH company, including extensometers, temperature chambers, probes, tools, protection covers etc.
- Due to high data acquisition rate **1kHz** and high resolution of AD converters **24 bit**, the measuring electronics allows very accurate testing in the large measuring range of the force sensor.
- Ability to control the machine with a remote control RMC7 with one button without PC.
- Support according standards: EN, DIN, ISO, ASTM, GOST, etc.

The base machine includes:

- The machine frame including length sensor and load cell
- Economical and silent Hydraulic unit with measuring and control electronic EDC 222
- Hydraulic connection between Hydraulic unit and frame
- Remote control RMC7 with LCD and emergency STOP button
- Remote control with integrated software

Supplements and Accessories

- Wide range of grips, compression and bending tools
- T-slotted plates
- Extensometers (mechanical, contactless)
- Safety covers
- Temperature chambers and furnaces



Software Test & Motion®

- Simple, intuitive and efficient
- Definable all kinds of protocols printing
- Individual files programming
- A set of programs for your own individual testing
- Available almost all standard methods of evaluation
- Special specific applications, programmable modules
- Digital display of all channels
- Extensive statistics results
- Saving of results data in ASCII format, SQL and Excel file
- Transferring data from other devices like touch thickness gauge, weight, etc.
- Compatibility with each EDC box system by LABORTECH company
- Possibility to add more additional channels
- Quick and efficient testing
- 9 languages (En, Cz, Ge, Fr, Pol, It, Sp, Ru, Du)
- Protocol printing in various languages
- Installation on any computer without a licence

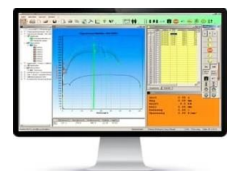

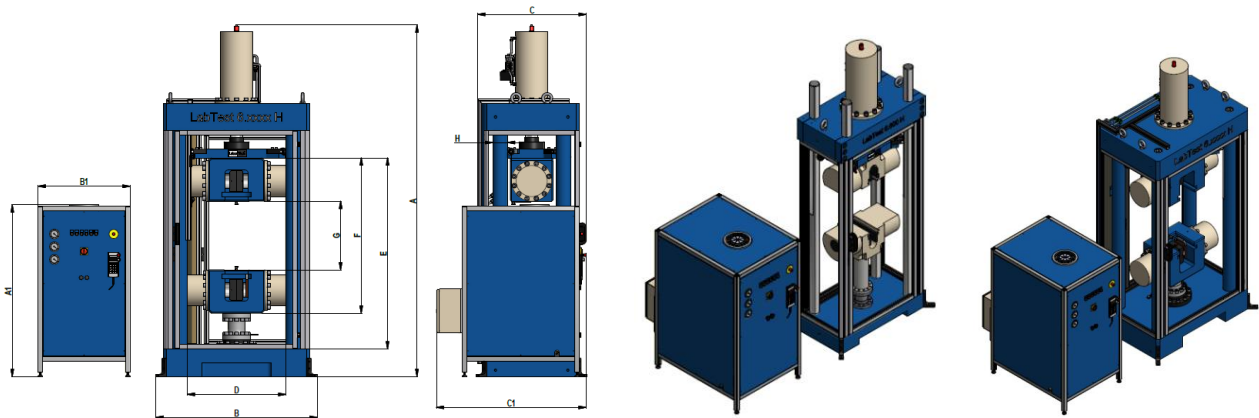

Technical data	Units	6.600H.2.31	6.1000H.2.41	6.1200H.2.41	6.1500H.2.41
Load capacity	kN	600	1000	1200	1500
Number of columns		4			
Piston stroke	mm	500	620	620	620
Minimum testing speed	mm/min	0,001			
Maximum testing speed	mm/min	440	250	220	250
Travel resolution	μm	1			
Accuracy of speed control	%	±0,05			
Weight without accessories	kg	2680	4720	4980	6200
Weight with grips ¹	kg	3270	5960	6200	7450
Color finish		RAL 1015, RAL 5015			
Dimensions					
Height of the machine (A)	mm	2950 ²	3050 ²	3050 ²	3620 ³
Width of the machine (B)	mm	1185	1405	1405	1445
Depth of the machine (C)	mm	685	1020	1020	1020
Width of test space (D)	mm	678	857	857	865
Height of test space (E)	mm	1637	1350	1350	2200
Height of test space with sensor (F)	mm	1060	1120	1120	1950
Height of test space between grips (G)	mm	500 ²	620 ²	620 ²	620 ³
Column diameter (H)		90	128	128	148
Height of hydraulic unit (A1)	mm	1490			1550
Width of hydraulic unit (B1)	mm	800			1100
Depth of hydraulic unit (C1)	mm	1311			1400
Environmental conditions					
Operating temperature	°C	10 to 35			
Storage temperature	°C	-35 to 55			
Humidity range	%	< 90			
Noise level ⁴	dB	< 65			
Electrical connection					
Supply voltage	V	3Ph/N/PE/400/50-60Hz			
Fuse	A	16	16	16	25
Power requirement (without accessories)	kVA	8,5	8,5	8,5	15

¹Hydraulic grips with side pressure

Technical changes are reserved by manufacturer

²Adjustable height of testing space max. + 300 mm – model type of series from 6.600H.2.xx.1 to 6.1200H.2.xx.1

³Adjustable height of testing space max. + 760 mm – model type of series 6.1500H.2.xx.1 and higher

⁴If is hydraulic unit covered in original cover from manufacturer. Measured at 1 m distance from hydraulic unit without load

Manufacturer:

LABORTECH s.r.o., Rolnická 130a, 747 05 Opava, Czech republic. Tel.: +420 553 731 956, +420 553 775 327
 Mob.: +420 602 527 646, +420 731 656 723, info@labortech.cz, www.labortech.cz, Czech republic

