

Product Information

Hydraulic Vertical Four Columns Testing Machines for Testing in Pressure **LabTest 6.xxxxH.4**

Machine use

Hydraulic four-column universal testing machines of the series H.4 with new design are intended for the mechanical tests in tensile, compression and bending for concrete plates, concrete cubes, girders and other components. Standard equipment includes a centrally placed, quiet and economical hydraulic drive. Due to machine series H.4 variability and wide range of accessories, it is possible to perform tests of any material in pressure at max. load 6 MN.

Machine description and the main advantages

- Open, four columns frame with high durability and ideal ergonomic configuration.
- Machine and working area ergonomic with sufficient width allows easy manipulation with specimens and accessories.
- Robustness ensures high rigidity and X-head deformation at full load 0.12 mm, the machine's lifespan and resistance to vibration into the floor.
- Quiet hydraulic drive with low noise <65 dB and power consumption, automatic control of oil level and temperature and cooling allow testing in 3-shift operation.
- Automatic check of the controlled loading in kN/sec or MPa/sec by proportional servo valve MOOG.
- A modular configuration of the machine with the ability to add any accessories from LABORTECH company that includes accessories for 3-point bending, special pressure plates, measuring probes etc.
- Measuring and evaluation desk with LCD display makes it simple to control and configure the testing press. A part of the desk is USB or LAN slot for communication with PC, an optional slot for connecting a printer for printing the protocol.
- Due to high data acquisition **1kHz** and high resolution of AD converters **24 bit**, the measuring electronics allows very precise testing in a large range of a load cell from 0,4% to 100% in max. range of the machine according to EN ISO 7500-1.
- Possibility to extend the machine with additional deformation sensors.
- Support according standards: DIN, EN, ISO, ASTM, GOST (EN 12390-4 / BS 1881:115 / DIN 51220, 51223, 51302).

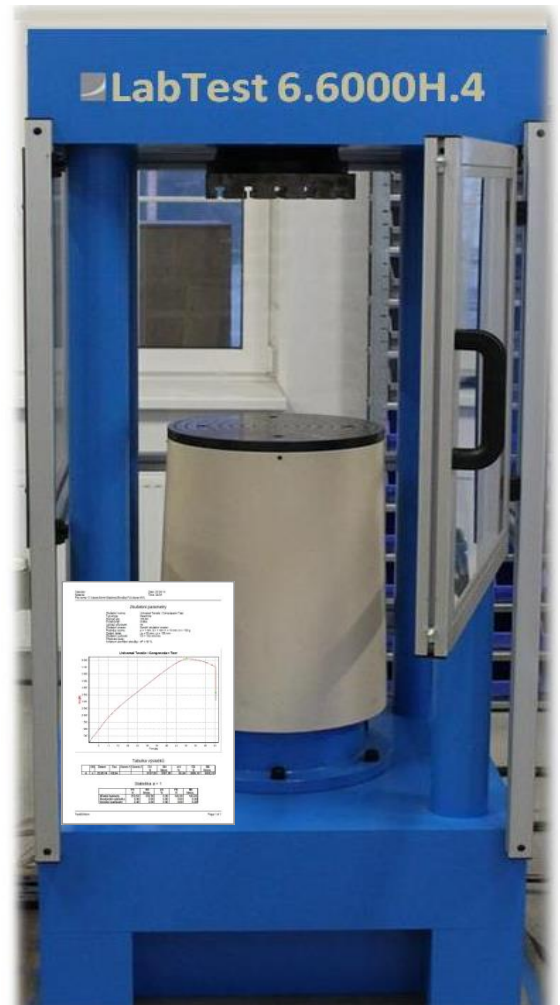

The basic machine includes:

- The frame including an oil load sensor
- Protective safety shield
- Economical, silent Hydraulic unit with cooling
- Measuring and control electronics EDC 222 with LCD and STOP button
- Hydraulic connection between hydraulic unit and the frame
- EDC 222 with integrated software

Supplements and Accessories

- Wide range of pressing tools
- Extensometers and track sensors for measuring the modulus of elasticity
- Safety shields with electronic check
- Possibility of a weighing machine for measuring the weight of concrete
- Testing software T&M – BASIC
- A printer for protocols printing directly from the machine



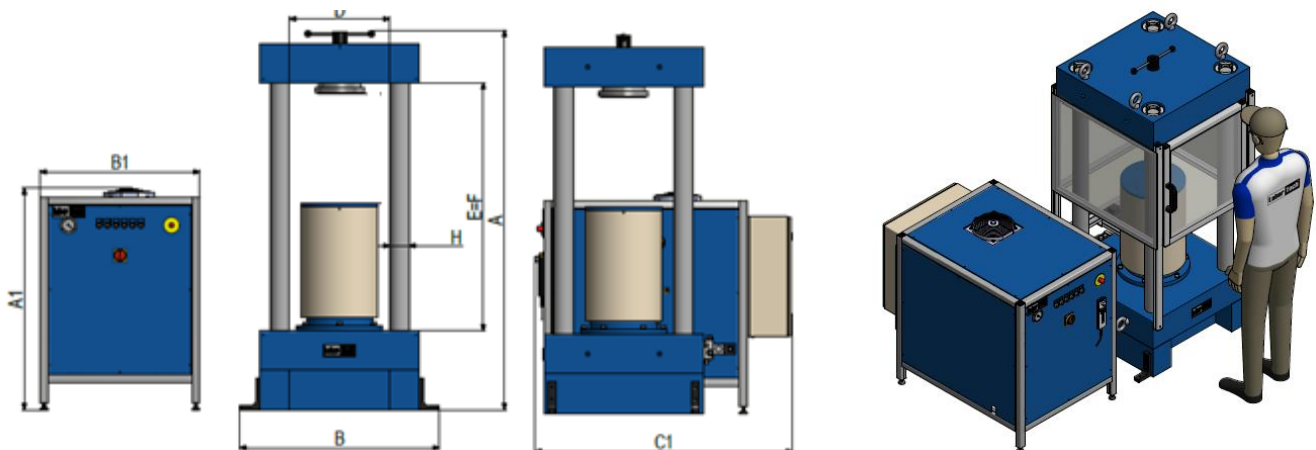

Technical data	Units	6.1000H.4	6.1500H.4	6.2000H.4	6.3000H.4	6.4000H.4	6.5000H.4	6.6000H.4	
Load capacity	kN	1000	1500	2000	3000	4000	5000	6000	
Number of columns		4							
Piston stroke	mm	100 – standard (possibility of increasing the stroke up to 300 mm)							
Type of Cylinder ¹		Single action cylinder – standard (possibility of double-cylinder)							
Maximum testing speed	mm/min	150	100	85	60	45	80	70	
Travel resolution ²		Accessories for Remainder - resolution up to 0.001 mm							
Accuracy of speed control	%	0,5							
Weight ³	kg	1860	2450	2710	2895	3120	4000	4680	
Color finish		RAL 1015, RAL 5015 (according to customer requirements)							
Dimensions									
Height of the machine (A)	mm	1650	1820	1820	1840	1840	2180	2180	
Width of the machine (B) ⁴	mm	940	1000	1000	1000	1000	1000	1000	
Depth of the machine (C)	mm	1000	1060	1060	1060	1060	1060	1060	
Width of test space (D)	mm	520	500	500	420	420	380	380	
Height of test space (E) ⁵	mm	500	500	500	460	460	400	400	
Column diameter (H)	mm	80	100	100	120	120	140	140	
Height of Hydraulic unit (A1)	mm	1102					1490		
Width of Hydraulic unit (B1)	mm	800					800		
Depth of Hydraulic unit (C1)	mm	1246					1240		
Environmental conditions									
Operating temperature	°C	10 to 35							
Storage temperature	°C	-35 to 55							
Humidity range	%	< 90							
Noise level ⁶	dB	< 65							
Electrical connection									
Supply voltage	V	3Ph/N/PE/400/50-60Hz							
Fuse	A	16	16	16	16	16	16	16	
Power requirement	kVA	4	4	4	4	4	8,5	8,5	

¹The standard version consists of a single-acting cylinder with 0,3 accuracy class oil sensor

Technical changes are reserved by manufacturer

²The length sensor is not in the standard version is only for an additional fee. You can use LVDT sensor type, IRC or SSI.

³Weight without hydraulic unit, force transducers and all accessories

⁴Dimensions including locking legs

⁵Height of test space without compression tools

⁶If the HU is covered with original manufacturer cover. Measured at 1 m distance from HU without loading

Manufacturer:

LABORTECH s.r.o., Rolnická 130a, 747 05 Opava, Czech republic. Tel.: +420 553 731 956, +420 553 775 327
Mob.: +420 602 527 646, +420 731 656 723, info@labortech.cz, www.labortech.cz, Czech republic

